

ENERGY/T

Scalzatore anteriore/reversibile singolo a tre punti
 Single Front/Reversible three point inter row
 Intercept avant/réversible simple avec connexion à trois points
 Stockräumer für vorderseite/umkehrbar

Attacco a tre punti frontale/reversibile
 Reversible/front three-point hitch
 Attelage trois points avant/réversible
 Dreipunktaufhängung vorne/umkehrbar

Tastatore a doppio effetto
 Double effect sensor
 Palpeur double effet
 Doppelleffektsonde

Rotazione +35° / -15°
 Rotation
 Rotation
 Drehung

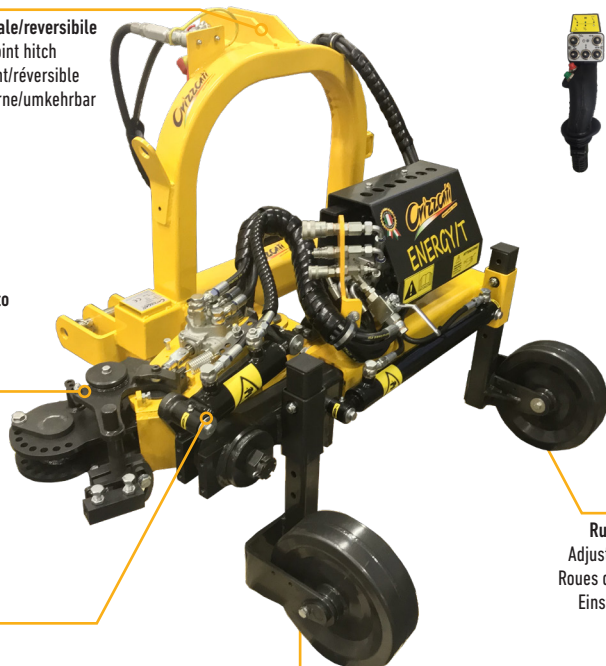

Ruote lisce di stabilità
 Adjustable smooth wheels
 Roues de stabilité réglables
 Einstellbare glatte Räder

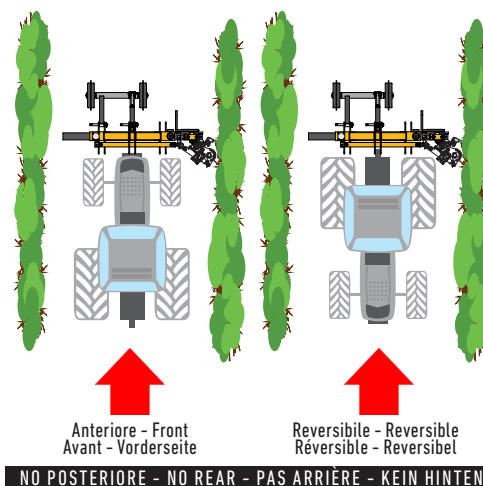

COD. 1035300J

Dati tecnici | Technical data | Fiche technique | Technische Daten

MOD.	MIN cm	MAX cm	hp min
ENERGY/T	170	40	60

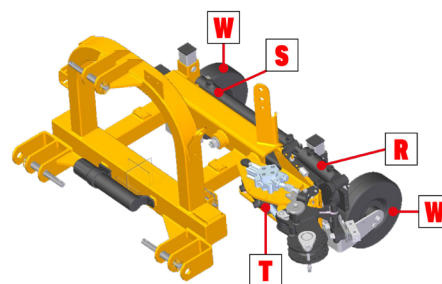

COD.	Manual	Tractor	Joystick	Distributor	Oil - Pressure	Kg
1035315I	3+1 W	R + T + S + ON/OFF MOTOR			30 lt/min 180 bar max	190
FUNZIONE " T " CON - " T " FUNCTION WITH - " T " FONCTION AVEC - " T " FUNKTION MIT						
1035300J	3+1 W	R + T + S + ON/OFF MOTOR			30 lt/min 180 bar max	200
1035316J	3+1 W	R + T + S + ON/OFF MOTOR +		PTO 540	PTO 540	285

ALLESTIMENTO ANTERIORE 1000 RPM SPECIFICARLO NELL'ORDINE - FRONT EQUIPMENT FOR 1000 RPM SPECIFY IT IN THE ORDER
 ÉQUIPEMENT FRONTAL POUR 1000 RPM PRÉCISEZ-LE À LA COMMANDE - VORDERE AUSTRÜSTUNG MIT 1000 U / min IN DER BESTELLUNG ANGEGBEN

OPTIONAL	Descrizione - Description - Description - Beschreibung	Kg
1A04810	Radiatore - Oil cooler Refroidisseur - Kühler	4
1A0350300	Valvola ripartitrice di olio per trattori oltre 50 lt/min. - Oil flow valve regulator for tractor over 50 lt/min. Régulateur d'huile pour tracteurs de plus de 50 l / min. - Ölverteilungsventil für Traktoren über 50 l / min.	
1U350007	Kit prolunga tastatore - Extra lower sensor Kit d'extension de palpeur - Sondenverlängerungskit	
1A48040	Serbatoio posteriore indipendente con radiatore, pompa Gr.3 e 60 lt olio - Independent oil tank with oil cooler, pump GR.3 and 60 lt. of oil Réservoir arrière indépendant avec radiateur, pompe Gr.3 et 60 litres d'huile - Unabhängiger hinterer Tank mit Kühler, Gr.3-Pumpe und 60 lt Öl	180

ESEMPI DI CONFIGURAZIONE - EXAMPLES OF CONFIGURATION - EXEMPLES DE CONFIGURATION - BEISPIELE FÜR DIE KONFIGURATION

ENERGY/T

Serbatoio olio
Oil tank
Reservoir
Öltank

Radiatore
Oil cooler
Refroidisseur
Kühler



Pump 540 RPM MAX



COD. 1035316J

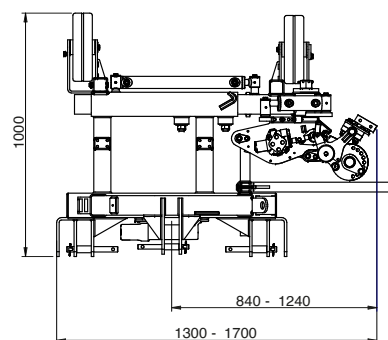
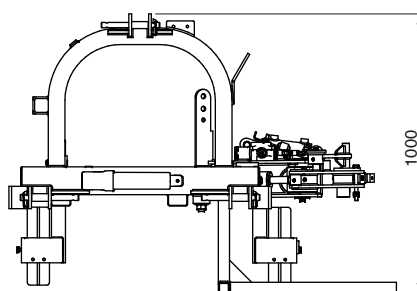
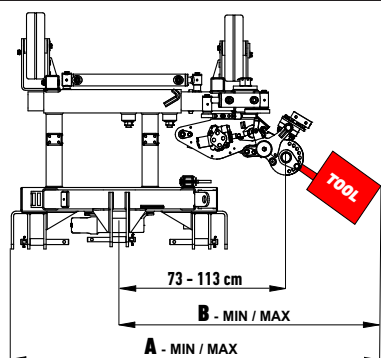

ATTREZZI PER LA LAVORAZIONE INTERFILARE - INTER-ROW WORKING TOOLS - OUTILS DE TRAVAIL INTERFIL - INTERFIL ARBEITSWERKZEUGE

INGOMBRO CON ATTREZZI DIMENSIONS WITH TOOLS DIMENSIONS AVEC OUTILS ABMESSUNGEN MIT WERKZEUGEN		COD.	A - MIN/MAX [cm]	B - MIN/MAX [cm]	INGOMBRO CON ATTREZZI DIMENSIONS WITH TOOLS DIMENSIONS AVEC OUTILS ABMESSUNGEN MIT WERKZEUGEN		COD.	A - MIN/MAX [cm]	B - MIN/MAX [cm]
	L 30 cm	1U35330	150 - 190	103 - 143		Ø 45 cm	1U35470	183 - 223	136 - 176
	L 50 cm	1U35340	159 - 199	112 - 152		Ø 60 cm	1U35480	198 - 238	151 - 191
	L 70 cm	1U35350	187 - 277	140 - 180		Ø 80 cm	1U35490	218 - 258	171 - 211
		1U35310	153 - 193	106 - 146		L 60 cm	1U35430	197 - 237	150 - 190
		1U35320				L 80 cm	1U35440	207 - 247	160 - 200
	Ø 30 cm	1U35230	158 - 198	111 - 151			1U35520	216 - 256	169 - 209
	Ø 40 cm	1U35240	163 - 203	116 - 156					
	Ø 50 cm	1U35250	168 - 208	121 - 161			1U35530	231 - 271	184 - 224
	2 el. Ø 31 cm	1U35000	162 - 202	115 - 155		Ø 45 cm	1U35290	166 - 206	119 - 159
	3 el. Ø 31 cm	1U35120	177 - 217	130 - 170		Ø 70 cm	1U35300	178 - 218	131 - 171
	4 el. Ø 31 cm	1U35150	192 - 232	145 - 185					
	5 el. Ø 36 cm	1U35156	206 - 246	159 - 199					
	1 el. Ø 46 cm	1U35170	144 - 184	97 - 137		2 el. Ø 36 cm	1U35580	165 - 205	118 - 158
	2 el. Ø 46 cm	1U35180	161 - 201	114 - 154		3 el. Ø 36 cm	1U35590	171 - 211	124 - 164
	3 el. Ø 46 cm	1U35190	178 - 218	131 - 171		4 el. Ø 36 cm	1U35610	177 - 217	130 - 170
	L 30 cm	1U35450	151 - 191	104 - 144		Ø 54 cm	1U35500	172 - 212	125 - 165
	L 60 cm	1U35460	159 - 199	112 - 152		Ø 70 cm	1U35506	181 - 221	134 - 174
						Ø 100 cm	1U35508	213 - 253	166 - 206
	L 60 cm	1U35421	180 - 220	133 - 173		L 30 cm	1U35513	159 - 199	112 - 152
	L 80 cm	1U35420	188 - 228	141 - 181		L 60 cm	1U35510	163 - 203	116 - 156

ATTREZZI - TOOLS - OUTILS - ZUBEHÖR

SCALZATORI INTERCEPPO - INTER-ROW MACHINE - DÉCHAUSSEUSES INTERCEPS - STOCKRÄUMER

Descrizione - Description - Description - Beschreibung		COD.	
	Ancora apripista Dozers anchor Ancre butteuse Spuröffnerhaken	DESTRO - Right - Droit - Rechts	1U35540
		SINISTRO - Left - Gauche - Links	1U35545
	Disco apripista liscio per scalzatore Ø = 31 cm Front smooth disc Ø 31 cm with inter-row attachment Disque de bulldozer lisse pour hoer Ø = 31 cm Glatte Bulldozerscheibe für Hacker Ø = 31 cm	DESTRO - Right - Droit - Rechts	1U35550
		SINISTRO - Left - Gauche - Links	1U35555
	Disco apripista dentato per scalzatore Ø = 31 cm Front teeth disc Ø 31 cm with inter-row attachment Disque de bulldozer denté pour hoer Ø = 31 cm Zahnrad-Planierscheibe für Hacker-Ø = 31 cm	DESTRO - Right - Droit - Rechts	1U35560
		SINISTRO - Left - Gauche - Links	1U35565
	Maggiorazione motore 250 cc - Extra charge for 250 cc engine Supplément pour moteur de 250 cc - Aufpreis für 250 cc Motor	MOD. VEGA / FAST / DUAL / VEGA MAXI	1U35570
	Attacco per secondo attrezzo fisso Attachment for second fix tools Fixation pour deuxième outil fixe Aufsatz für zweites festes Werkzeug	CADAUNO / Each / Chaque / Pro Stk.	 1U35575

Descrizione - Description - Description - Beschreibung	L. cm	Oil (lt/min)	Kg	Ø	COD.
	8 cm	25	25	Ø 31 cm DESTRO - Right - Droit - Rechts	1U35000
	8 cm			Ø 31 cm SINISTRO - Left - Gauche - Links	1U35005
	12 cm			Ø 36 cm DESTRO - Right - Droit - Rechts	1U35100
	12 cm			Ø 36 cm SINISTRO - Left - Gauche - Links	1U35105
	14 cm			Ø 41 cm DESTRO - Right - Droit - Rechts	1U35110
	14 cm			Ø 41 cm SINISTRO - Left - Gauche - Links	1U35115
	8 cm	28	35	Ø 31 cm DESTRO - Right - Droit - Rechts	1U35120
	8 cm			Ø 31 cm SINISTRO - Left - Gauche - Links	1U35125
	12 cm			Ø 36 cm DESTRO - Right - Droit - Rechts	1U35130
	12 cm			Ø 36 cm SINISTRO - Left - Gauche - Links	1U35135
	14 cm			Ø 41 cm DESTRO - Right - Droit - Rechts	1U35140
	14 cm			Ø 41 cm SINISTRO - Left - Gauche - Links	1U35145
	8 cm	33	70	Ø 31 cm DESTRO - Right - Droit - Rechts	1U35150
	8 cm			Ø 31 cm SINISTRO - Left - Gauche - Links	1U35155
	12 cm	36	82	Ø 36 cm DESTRO - Right - Droit - Rechts	1U35156
	12 cm			Ø 36 cm SINISTRO - Left - Gauche - Links	1U35157
	20	36	82	1 d. DESTRO - Right - Droit - Rechts	1U35170
	20			1 d. SINISTRO - Left - Gauche - Links	1U35175
	40			2 d. DESTRO - Right - Droit - Rechts	1U35180
	40			2 d. SINISTRO - Left - Gauche - Links	1U35185
	60			3 d. DESTRO - Right - Droit - Rechts	1U35190
	60			3 d. SINISTRO - Left - Gauche - Links	1U35195



Dischiera colmatrice motorizzata Ø 46 cm
Motorized disc group filler Ø 46 cm
Buteuse à 1 disque motorisée Ø 46 cm
1 Motorisierter Anhäufelscheiben Ø 46 cm

20	25	30	1 d. DESTRO - Right - Droit - Rechts	1U35200
20	25	30	1 d. SINISTRO - Left - Gauche - Links	1U35205
40	28	46	2 d. DESTRO - Right - Droit - Rechts	1U35210
40	28	46	2 d. SINISTRO - Left - Gauche - Links	1U35215
60	30	54	3 d. DESTRO - Right - Droit - Rechts	1U35220
60	30	54	3 d. SINISTRO - Left - Gauche - Links	1U35225

Descrizione - Description - Description - Beschreibung	N°	L. cm	Oil (l/min)	Kg	Ø	COD.	Price
--	----	-------	-------------	----	---	------	-------



Rotofresa
Motorhoes
Fraise rotative
Drehfräse

3	30	4÷8 cm	25	40	Ø 30 cm DESTRO - Right - Droit - Rechts	1U35230
3	30		25	40	Ø 30 cm SINISTRO - Left - Gauche - Links	1U35235
4	40		28	45	Ø 40 cm DESTRO - Right - Droit - Rechts	1U35240
4	40		28	45	Ø 40 cm SINISTRO - Left - Gauche - Links	1U35245
4	50		32	50	Ø 50 cm DESTRO - Right - Droit - Rechts	1U35250
4	50		32	50	Ø 50 cm SINISTRO - Left - Gauche - Links	1U35255



Supporto per coltelli flottanti per aree sassose
Device for mobile knives motor hoes for stone area
Support des couteaux flottant pour terrain de pierre
Unterstützung für Schwimmmesser für steinige Bereiche

Ø 30 cm	1U35260
Ø 40 cm	1U35265
Ø 50 cm	1U35270



Protezione paraterra per rotofresa
Protection for motor hoes
Déflecteur pour fraise
Bodenschutz für Rollschneider

DESTRO - Right - Droit - Rechts	1U35280
SINISTRO - Left - Gauche - Links	1U35285



Spazzola metallica in acciaio
Metal brush
Brosse métallique en acier
Stahlbürste

2÷3 cm	28	65	Ø 45 cm DESTRO - Right - Droit - Rechts	1U35290
2÷3 cm	28	65	Ø 45 cm SINISTRO - Left - Gauche - Links	1U35295
2÷3 cm	32	70	Ø 70 cm DESTRO - Right - Droit - Rechts	1U35300
2÷3 cm	32	70	Ø 70 cm SINISTRO - Left - Gauche - Links	1U35305



Paletta pulisci tronco
Tree trunk cleaner
Cure-ceps pour debuteuse
Baumstammreiniger

DESTRO - Right - Droit - Rechts	1U35160
SINISTRO - Left - Gauche - Links	1U35165







Lama paraterra di contenimento
Blade restraint
Déflecteur pour zone enherbée
Begrenzungsblech



MIRA - ORION - JOLLY ENERGY/T - ENERGY/S	1U35386
ECO VEGA	1U35416
VEGA	1U35391
MITO - POLARE	1U35396
VEGA MAXI	1U35401
FAST	1U35406
DUAL/P - DUAL/T DUAL/S	1U35411



Descrizione - Description - Description - Beschreibung			Kg	COD.
	Aratrino calandrato Plough Decavaillonneuse Pflug	10÷15 cm	21	VIGNETO / Vineyard / Vigne / Weinberg DESTRO - Right - Droit - Rechts 1U35310
			21	VIGNETO / Vineyard / Vigne / Weinberg SINISTRO - Left - Gauche - Links 1U35315
			25	FRUTTETO / Orchard / Verger / Obstgarten DESTRO - Right - Droit - Rechts 1U35320
			25	FRUTTETO / Orchard / Verger / Obstgarten SINISTRO - Left - Gauche - Links 1U35325
	Lama estiva Summer blade Lama interceps Sommermesser	3÷5 cm	10	L 30 cm DESTRO - Right - Droit - Rechts 1U35330
			10	L 30 cm SINISTRO - Left - Gauche - Links 1U35335
			11	L 50 cm DESTRO - Right - Droit - Rechts 1U35340
			11	L 50 cm SINISTRO - Left - Gauche - Links 1U35345
			13	L 70 cm DESTRO - Right - Droit - Rechts 1U35350
	13	L 70 cm SINISTRO - Left - Gauche - Links 1U35355		
	Deflettore per lama estiva Deflector for summer blade Déflecteur pour lame interceps Deflektor für Sommerklinge		L. 30cm = 1; L. 50cm = 2; L. 70cm = 3	1U35380
	Paletta pulisci ceppo per lama estiva Tree trunk cleaner for summer blade Curé-ceps pour lame interceps Baumstammreiniger für Sommerklinge			DESTRO - Right - Droit - Rechts 1U35360
				SINISTRO - Left - Gauche - Links 1U35365
	Sponda laterale per lama estiva Lateral side for summer blade Versoir pour lame interceps Seitliche Seite für Sommerklinge			DESTRO - Right - Droit - Rechts 1U35370
				SINISTRO - Left - Gauche - Links 1U35375

Descrizione - Description - Description - Beschreibung	N°	L. cm	Ø mm		Oil (l/min)	Kg	COD.
	7	70	4	15+15 cm	25	60	600 DESTRO - Right - Droit - Rechts 1U35421
	7	70	4	15+15 cm	25	60	600 SINISTRO - Left - Gauche - Links 1U35426
	9	70	4	15+15 cm	25	70	800 DESTRO - Right - Droit - Rechts 1U35420
	9	70	4	15+15 cm	25	70	800 SINISTRO - Left - Gauche - Links 1U35425
	3x	40	4		25	30	30 cm DESTRO - Right - Droit - Rechts 1U35450
	3x	40	4		25	30	30 cm SINISTRO - Left - Gauche - Links 1U35455
	3x	40	4		25	38	60 cm DESTRO - Right - Droit - Rechts 1U35460
	3x	40	4		25	38	60 cm SINISTRO - Left - Gauche - Links 1U35465
	3x	40	4		25	42	80 cm DESTRO - Right - Droit - Rechts 1U35462
	3x	40	4		25	42	80 cm SINISTRO - Left - Gauche - Links 1U35463
	Mini trincia con mazze Mini cutter with hammer Mini broyeur avec marteaux Mini mulcher mit Hämmern				30	60	60 cm DESTRO - Right - Droit - Rechts 1U35430
					30	60	60 cm SINISTRO - Left - Gauche - Links 1U35435
		N° 10 - L. 60 cm			30	75	80 cm DESTRO - Right - Droit - Rechts 1U35440
		N° 14 - L. 80 cm			30	75	80 cm SINISTRO - Left - Gauche - Links 1U35445

Descrizione - Description - Description - Beschreibung	cm	Oil (l/min)	Kg	Ø	COD.	
	Ruota interfilare modello DT Disc mower model DT Tondeuse interceps modèle DT Mähscheibe Modell DT	2	25	55	Ø 45 cm DESTRO - Right - Droit - Rechts 1U35470	
		2	25	55	Ø 45 cm SINISTRO - Left - Gauche - Links 1U35475	
		2	28	70	Ø 60 cm DESTRO - Right - Droit - Rechts 1U35480	
		N° 2 - Ø 45 cm	2	28	70	Ø 60 cm SINISTRO - Left - Gauche - Links 1U35485
		N° 2 - Ø 60 cm	2	32	85	Ø 80 cm DESTRO - Right - Droit - Rechts 1U35490
	N° 3 - Ø 80 cm	2	32	85	Ø 80 cm SINISTRO - Left - Gauche - Links 1U35495	

Descrizione - Description - Description - Beschreibung		N°	Ø	Kg		COD.
 <p>Disco folle "BIO SPEED" Disc group in neutral "BIO SPEED" Disque émotteur "BIO SPEED" Leerlaufscheibe "BIO SPEED"</p>		2		35	DESTRO - Right - Droit - Rechts	1U35580
				35	SINISTRO - Left - Gauche - Links	1U35585
		3	Ø 36	41	DESTRO - Right - Droit - Rechts	1U35590
				41	SINISTRO - Left - Gauche - Links	1U35595
		4		53	DESTRO - Right - Droit - Rechts	1U35610
				53	SINISTRO - Left - Gauche - Links	1U35615
	 <p>Rototerra meccanico Mechanical rotor Herse mécanique Fingerhacke</p> <p>HARD</p>			15	DESTRO - Right - Droit - Rechts	1U35498
				Ø 37	15	SINISTRO - Left - Gauche - Links
				30	DESTRO - Right - Droit - Rechts	1U35500
			Ø 54	30	SINISTRO - Left - Gauche - Links	1U35505
				45	DESTRO - Right - Droit - Rechts	1U35506
			Ø 70	45	SINISTRO - Left - Gauche - Links	1U35507
 <p>Rototerra meccanico Mechanical rotor Herse mécanique Fingerhacke</p> <p>MEDIUM</p>			27	DESTRO - Right - Droit - Rechts	1U35501	
			Ø 54	27	SINISTRO - Left - Gauche - Links	1U35502
				38	DESTRO - Right - Droit - Rechts	1U35503
			Ø 70	38	SINISTRO - Left - Gauche - Links	1U35504
				62	DESTRO - Right - Droit - Rechts	1U35508
			Ø 100	62	SINISTRO - Left - Gauche - Links	1U35509
 <p>Rototerra meccanico Mechanical rotor Herse mécanique Fingerhacke</p> <p>SOFT</p>			66	DESTRO - Right - Droit - Rechts	1U35496	
			Ø 100	66	SINISTRO - Left - Gauche - Links	1U35497

Descrizione - Description - Description - Beschreibung		N°	Ø mm	Oil (lt/min)	Kg		COD.
 <p>Spollonatore Shoot removing head Empampreuse Rebstammputzer</p>		13	700	15	38	DESTRO - Right - Droit - Rechts	1U35510
		13	700	15	38	SINISTRO - Left - Gauche - Links	1U35515
 <p>Girami per vigneto Pruning rake for vineyards Andaineur pour vignoble Kehrbesen für Weinberge</p>		112	8	25	42	DESTRO - Right - Droit - Rechts	1U35520
		112	8	25	42	SINISTRO - Left - Gauche - Links	1U35525
 <p>Girami per frutteto Pruning rake for orchard Andaineur pour verger Kehrbesen für Obstplantagen</p>		136	6	25	48	DESTRO - Right - Droit - Rechts	1U35530
		136	6	25	48	SINISTRO - Left - Gauche - Links	1U35535

Descrizione - Description - Description - Beschreibung	L. cm	Oil (lt/min)	Kg		COD.		
 <p>Erpice interfilare Power arrow Herse inter-rangs Zwischenreihenegge</p>	N° 2	20 cm	30	40	DESTRO - Right - Droit - Rechts	1U35650	
					SINISTRO - Left - Gauche - Links	1U35651	
	N° 3	20 cm	30	55	DESTRO - Right - Droit - Rechts	1U35652	
					SINISTRO - Left - Gauche - Links	1U35653	
N° 4	20 cm	30	75	DESTRO - Right - Droit - Rechts	1U35654		
				SINISTRO - Left - Gauche - Links	1U35655		
 <p>Fresa interfilare Inter-row miller Fraises intercept Folge</p>	L. 30 cm	30	10 cm	28	38	DESTRO - Right - Droit - Rechts	1U35656
	L. 60 cm	60	10 cm	28	45	DESTRO - Right - Droit - Rechts	1U35658

